

# MEA-GNSS-LTE

## 2 IN 1 LTE/GNSS ANTENNA

Ordering Part #: 100-00103-01

The MEA-GNSS-LTE is a 2 in 1 low profile antenna solution by Maxtena that combines GNSS and LTE antennas in one. Our low profile 2 in 1 solution is ideal for asset tracking, industrial and IOT applications. This antenna offers a ultra low profile rugged IP67 rated design with easy mounting and customizable cables and connector options. The small size make this antenna a desirable solution for covert installations.



### Features

- Covers GNSS & LTE Bands
- 2 in 1 Low Profile Antenna
- Rugged IP67
- Customizable Cables and Connectors
- Small Size
- Easy Adhesive Mounting
- Quality Textured Covert Design

### Applications

- Asset Tracking
- Telematics
- Container & Logistics
- Automotive
- Industrial Applications
- IOT Applications

#### GPS-GLONASS Antenna Electrical Specifications

Frequency Range (MHz)	1575.42 / 1602 MHz
VSWR	2.0 : 1 Max
Impedance	50 Ohm
Polarization	Linear
Gain @ Zenith	1 dBi Typ. @ 1575 MHz 1 dBi Typ. @ 1602 MHz

#### LNA Electrical Properties

Frequency Range (MHz)	1575.42 / 1602 MHz
VSWR	2.0 : 1 Max
Impedance	50 Ohm
Antenna Gain (@ 3.3V)	28 dB Typ. / 25 dB Min
DC Power Input	3~5 V
Noise Figure	2.5 dB Typ.
Power Consumption (@ 3.3V)	9 mA Typ.

#### LTE Antenna Electrical Specifications

Frequency Range (MHz)	698~960 / 1710~2170 / 2300~2690 MHz
VSWR	698~960 MHz $\leq$ 3.7 1710~2170 MHz $\leq$ 3.5 2300~2690 MHz $\leq$ 3.0
Impedance	50 Ohm
Peak Gain	1.0 dBi Typ. @ 698~960 MHz 2.0 dBi Typ. @ 1710~2170 MHz 2.0 dBi Typ. @ 2300~2690 MHz
Average Efficiency	698~960 MHz $\geq$ 28% 1710~2170 MHz $\geq$ 30% 2300~2690 MHz $\geq$ 30%

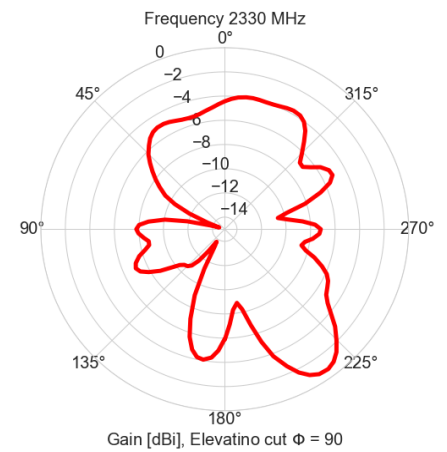
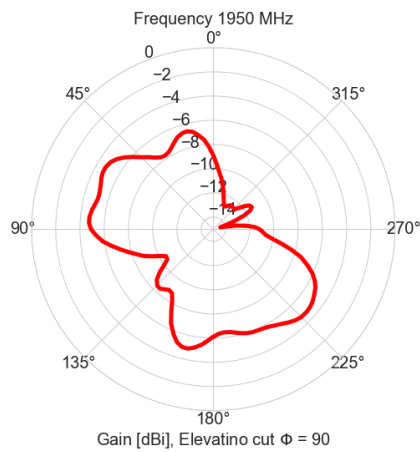
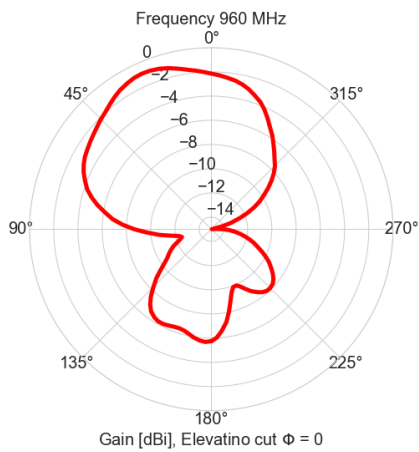
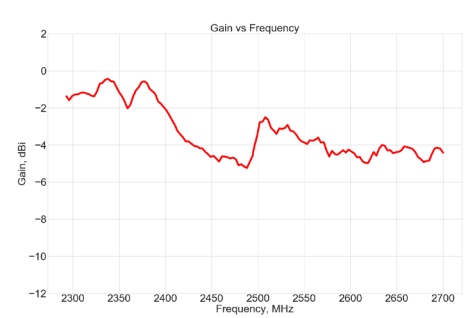
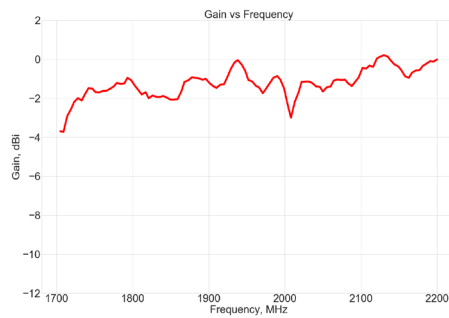
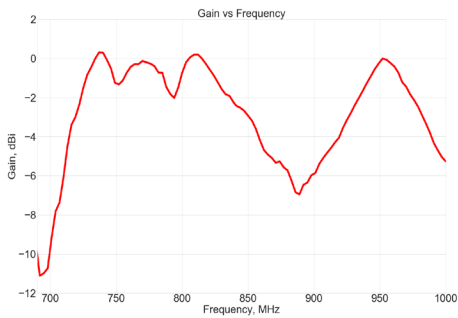
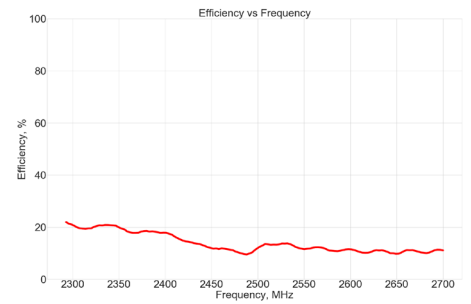
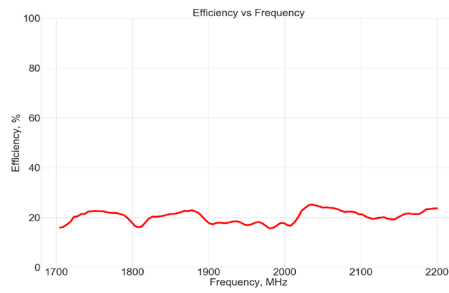
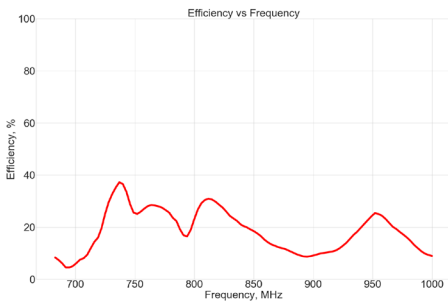
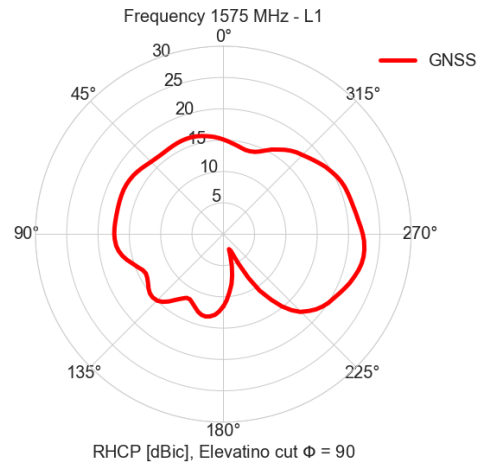
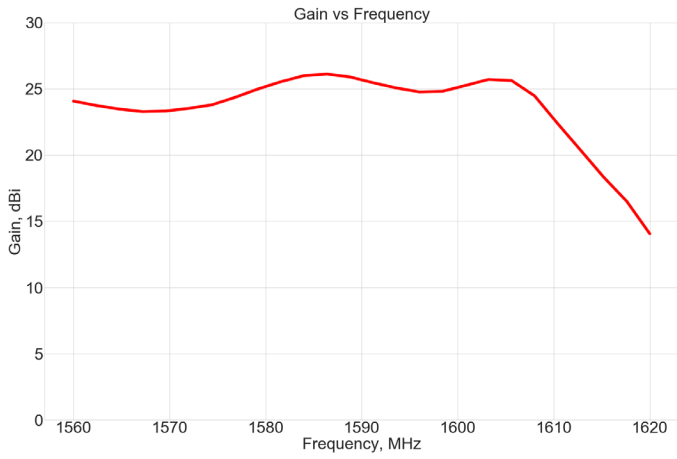

### Mechanical Specifications

Antenna Dimensions (mm)	Diameter 51.4 x (h) 11.7 mm
Mounting Function	Adhesive Mount
Operating Temperature	-40 °C + 85 °C
Housing Material & Color	PC & Black
Cable	RG-174
Cable Length	1 Meter
Connector	SMA / FAKRA or customer specification
Waterproof	IPX5

DRAWING REVISION HISTORY			
REV	DESCRIPTION	DATE	BY
A	INITIAL RELEASE	2021-03-19	QZ

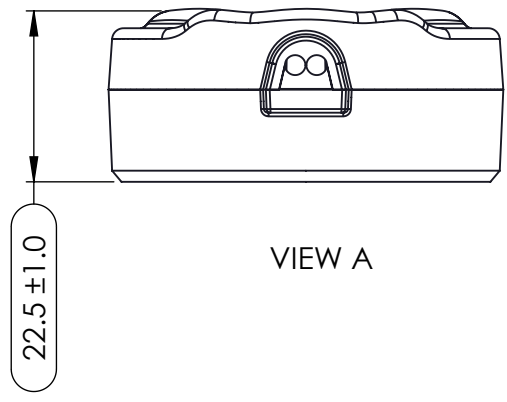
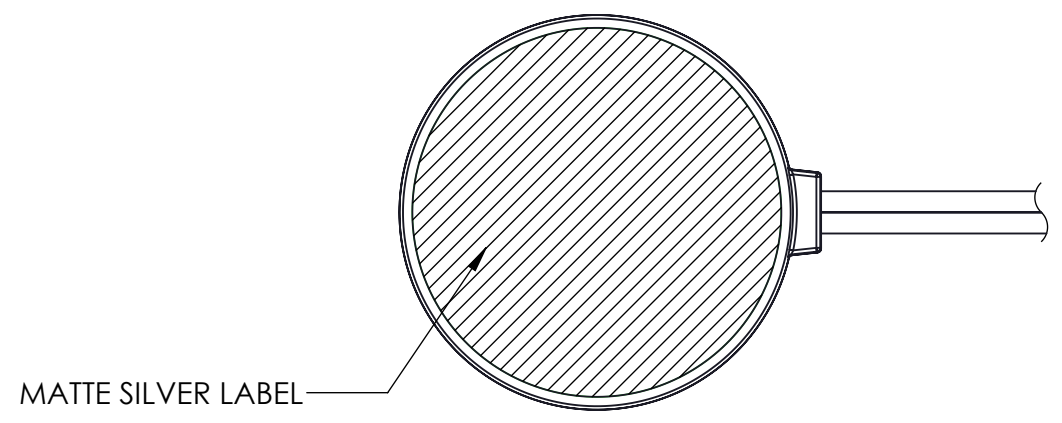
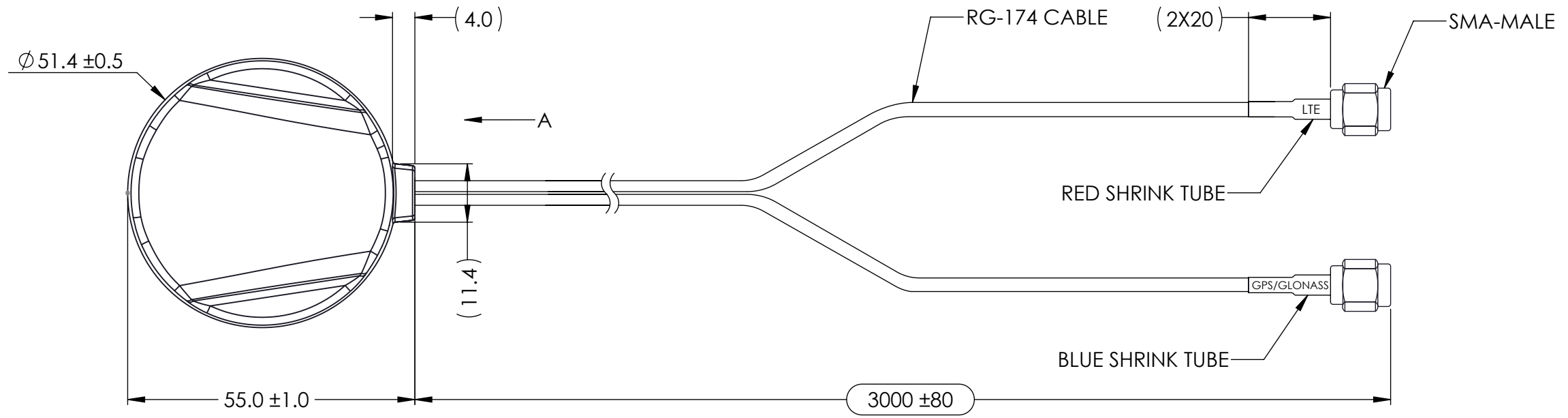

- NOTES:
- FREQUENCY:  
GPS-GLONASS ACTIVE ANTENNA: 1575.42MHZ/1602 MHZ  
LTE PASSIVE ANTENNA: 698~960/1710~2170/2300~2700 MHZ
  - CONNECTOR: SMA-MALE
  - MOUNTING TYPE: ADHESIVE MOUNT
  - WATERPROOF: IPX5.
  - INSPECTION DIMENSIONS MARK AS (DIM) , REFERENCE DIMENSIONS MARK AS (DIM).

ITEM 100-00103-01 REVISION HISTORY			
REV	DESCRIPTION	DATE	BY
A	INITIAL RELEASE	2021-03-19	QZ

PROPRIETARY AND CONFIDENTIAL

THE INFORMATION CONTAINED IN THIS DRAWING IS THE SOLE PROPERTY OF MAXTENA, INC. ANY REPRODUCTION IN PART OR AS A WHOLE WITHOUT THE WRITTEN PERMISSION OF MAXTENA, INC IS PROHIBITED.

UNLESS OTHERWISE SPECIFIED:

DIMENSIONS ARE IN MM  
TOLERANCES:  
FRACTIONAL ±  
ANGULAR: MACH ± .5° BEND ±  
INTEGER: ± 2  
ONE PLACE DECIMAL ± 1.0

INTERPRET GEOMETRIC TOLERANCING PER:

THIRD ANGLE PROJECTION

DO NOT SCALE DRAWING

	NAME	DATE
DRAWN	QZ	2021-03-19
CHECKED	ZX	2021-03-22
ENG APPR.	NPC	2021-03-23
MFG APPR.		
	Q.A.	

CAD MAINTAINED. CHANGES SHALL BE INCORPORATED BY THE DESIGN ACTIVITY.

MAXTENA, INC

TITLE: 100-00103-01 MEA-GNSS-LTE

SIZE B DWG. NO. 117-00374-01 REV A

CAGE CODE: 5KQH7 SCALE: NONE SHEET 1 OF 1